

User Guide

BMC9012
BMC9022D
Broadband
Media Center



MOTOROLA
intelligence everywhere™



Copyright © 2004 Motorola, Inc.

All rights reserved. No part of this publication may be reproduced in any form or by any means or used to make any derivative work (such as translation, transformation or adaptation) without written permission from Motorola, Inc.

Motorola reserves the right to revise this publication and to make changes in content from time to time without obligation on the part of Motorola to provide notification of such revision or change. Motorola provides this guide without warranty of any kind, implied or expressed, including but not limited to, the implied warranties of merchantability and fitness for a particular purpose. Motorola may make improvements or changes in the product(s) described in this manual at any time.

Motorola and the Stylized M Logo are registered in the US Patent & Trademark Office. Digeo, the Digeo logo, the Moxi logo and combinations thereof are trademarks of Digeo, Inc. in the USA and other countries. All other product, service or brand names are the property of their respective owners.

Manufactured under license from Dolby Laboratories. "Dolby" and the double-D symbol are trademarks of Dolby Laboratories.

This product incorporates copyright protection technology that is protected by U.S. patents and other intellectual property rights. Use of this copyright protection technology must be authorized by Macrovision Corporation, and is intended for home and other limited consumer uses only unless otherwise authorized by Macrovision. Reverse engineering or disassembly is prohibited.

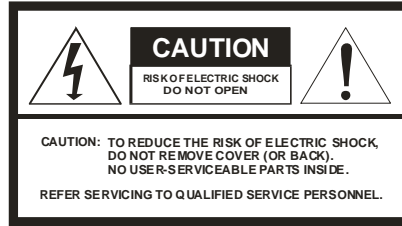

Graphical symbols and supplemental warning markings on the back of the terminal

WARNING

TO PREVENT FIRE OR SHOCK HAZARD, DO NOT EXPOSE THIS APPLIANCE TO RAIN OR MOISTURE.

CAUTION

TO PREVENT ELECTRICAL SHOCK, DO NOT USE THIS PLUG WITH AN EXTENSION CORD, RECEPTACLE, OR OTHER OUTLET UNLESS THE BLADES CAN BE FULLY INSERTED TO PREVENT BLADE EXPOSURE.

TO PREVENT OVERHEATING, SITUATE THE PRODUCT AWAY FROM HEAT SOURCES SUCH AS RADIATORS, HEAT REGISTERS, STOVES, OR OTHER PRODUCTS (INCLUDING AMPLIFIERS) THAT PRODUCE HEAT.



The lightning flash with arrowhead symbol, within an equilateral triangle, is intended to alert the user to the presence of uninsulated “dangerous voltage” within the product’s enclosure that may be of sufficient magnitude to constitute a risk of electric shock to persons.



The exclamation point, within an equilateral triangle, is intended to alert the user to the presence of important operating and maintenance (servicing) instructions in the literature accompanying the appliance.

INSTALLATION

This installation should be made by a qualified service person and should conform to all local codes.



This equipment operates over the marked Voltage and Frequency range without requiring manual setting of any selector switches. Different types of line cord sets may be used for connections to the mains supply circuit and should comply with the electrical code requirements of the country of use.



Coaxial Connections – To reduce the risk of fire, use only No. 26 AWG or larger coaxial cable or equivalent.

REPAIRS

If you find the unit in need of repair, contact your cable system operator for repair or replacement.

NOTE TO CATV SYSTEM INSTALLER

This reminder is provided to call the CATV system installer’s attention to Article 820-40 of the NEC that provides guidelines for proper grounding and, in particular, specifies that the cable ground shall be connected to the grounding system of the building, as close as possible to the point of cable entry as practical.

EXAMPLE OF ANTENNA GROUNDING

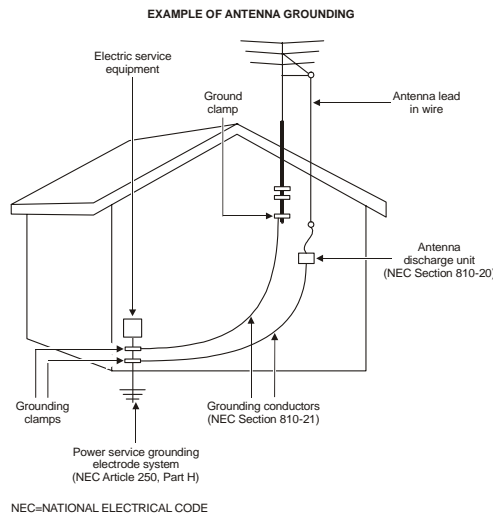

Table of Contents

Introduction	2
BMC Features	2
BMC Diagrams.....	3
Front View	3
Back View.....	3
Installation	4
Ventilation Requirements	4
Equipment Required	5
BMC Connection Procedure.....	5
Digital Video/Digital Audio Connection.....	6
Digital Video/Stereo Audio Connection.....	6
Component Video/Digital Audio Connection	7
Component Video/Stereo Audio Connection	7
S-Video/Stereo Audio Connection.....	8
Composite Video/Stereo Audio Connection	9
Installation Wrap-Up	10
Audio Configuration	10
Video Configuration	11
Video Settings Definitions.....	12
Moxi Remote	13
Programming Procedure	13
Television Codes	14
Audio/Video Receiver Codes	17

Chapter 1

Introduction

The Motorola Broadband Media Center (BMC) family of products delivers digital video and audio, plus a whole new experience in interactive cable television. Finding what you want to watch and watching it when you want has never been easier. The BMC is simple to set up and easy to operate. The BMC9022D extends all its features to a second TV in your home.

This guide introduces you to the features and setup of your BMC. Refer to the *Moxi Viewer's Guide* to learn more about operating the BMC and some of the advanced features these models provide.

BMC Features

Standard Features of the BMC9012 and the BMC9022D

- Dual analog/digital cable video tuners
- Integrated HDTV decoder
- Integrated Digital Video Recorder (DVR)
- Integrated DOCSIS cable modem
- High quality interactive graphics
- S-video output
- Digital audio (S/PDIF coaxial and optical) outputs
- Digital Video Interface (DVI)* output
- Stereo audio output
- Component video (YPrPb) output
- Two USB 1.1 (front) and two USB 2.0 (back) connectors
- 10/100 Base-T Ethernet connector
- Clock display
- Front panel control buttons
- AV outputs

Additional Features of the BMC9022D

In addition to the standard features listed above, the BMC9022D includes the following:

- CD/DVD optical drive
- Support for second TV via Media Center Extension (Moxi Mate) device

Specifications of the BMC9012 and the BMC9022D

- Power supply: line input voltage 95V - 125V AC; frequency 57Hz - 63Hz
- USB power: two connectors front, 5V, 500mA max combined current
- USB power: two connectors rear, 5V, 500mA max combined current
- DVI power 5V, 100mA max current
- Operating temperature: 15°C - 40°C
- Dimensions (W x H x D): 17" x 3.3" x 12"
- Weight: approximately 15 pounds

* The DVI port may not be enabled at this time. Once the port is enabled, you can reconnect your HDTV, provided it has an HDCP-compliant DVI port.

BMC Diagrams

The following illustrations identify the controls on the BMC. Slight variations may exist between these illustrations and your model.

Front View

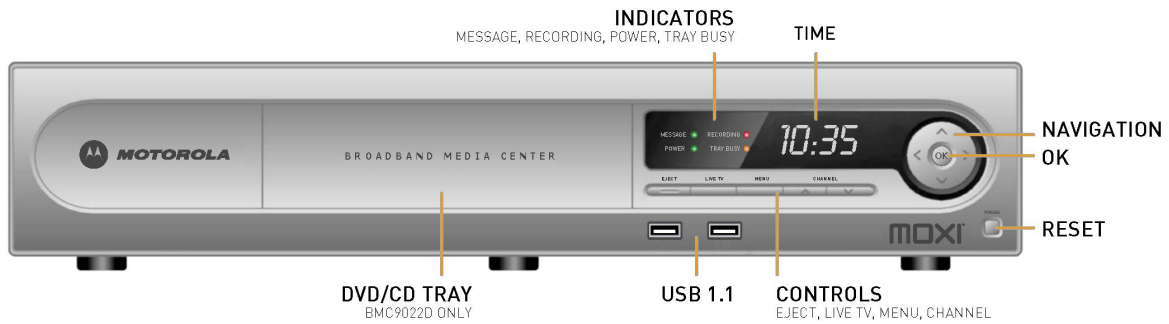

Figure 1: BMC Front

Back View

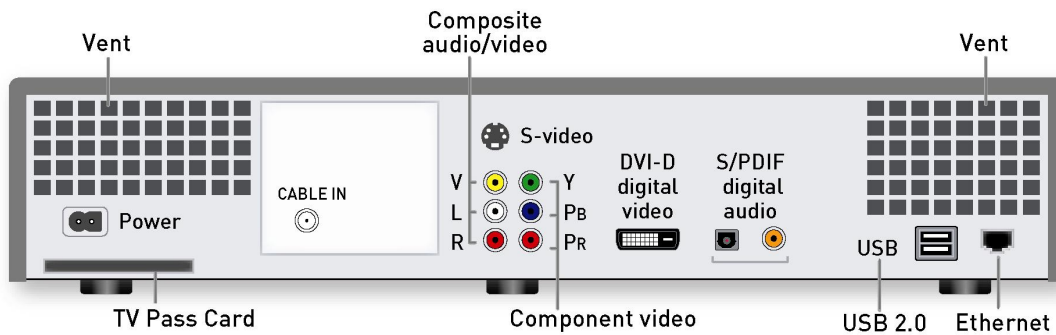

Figure 2: BMC Back

Chapter 2

Installation

This chapter describes how to install the BMC and verify the installation. The chapter also contains information to help you successfully disconnect, move, and reconnect the cable connections between the BMC and the TV.

When connecting the BMC, make sure all coaxial connections are "finger-tight"—secure, but not so tight they cannot be undone with your fingers. You do not need any special tools to disconnect the BMC, although you may need a wrench to loosen any tight connections.

Warnings



- Do not connect the BMC unit to any switched power source.
- Do not operate the BMC on its side (vertically).
- Use only the power cord supplied with the BMC and use that cord only for the BMC.
- Keep the BMC on, unless moving or servicing the unit. If power is removed, or a power outage occurs, it will take several minutes after power is restored for the unit to resume normal operations.

Ventilation Requirements

Allow adequate ventilation and airflow around the BMC to prevent overheating.

Warnings



- Cabinet installations must have open airflow or no doors.
- Vents must be unobstructed and open to surrounding air.
- Ensure top, side, and back clearance of at least two inches.
- Keep away from other heat-generating devices.

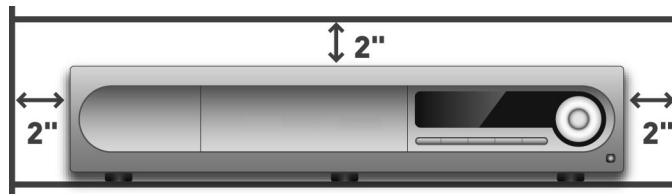

Figure 3: BMC Ventilation

Equipment Required

- Video cable (Composite, S-Video, Component (YPrPb) or DVI-D) for TV/Monitor
- Audio cable (Stereo Analog, Digital Coaxial, or Optical) for TV and/or audio system

Use the best connection supported by your TV, monitor, or audio system.

See the wiring diagrams starting on page 6 for reference.

BMC Connection Procedure

The installation scenarios described in this section apply to all BMCs, including the BMC9012 and the BMC9022D. Use the information in this section and the accompanying wiring diagrams to install the BMC9012 or the BMC9022D.

The BMC allows multiple types of audio and video connections. We recommend you use the best connection that your TV and audio system supports. Refer to the documentation that came with your TV or audio device for specific information on what the device supports.

The BMC9022D includes an optional Media Center Extension device (Moxi Mate) to control a second TV in the home. If you use both the BMC9022D and the Moxi Mate, follow the steps below to connect the BMC9022D to the main TV, and refer to the *Moxi Mate Hardware Manual* for the Moxi Mate installation instructions.

1. Before you begin, make sure both the TV and the BMC are turned off and all connections are unplugged.
2. Position the BMC in a well-ventilated open area near the TV and/or audio receiver.
3. Connect the incoming cable supply to the BMC. Attach one end of the coaxial cable to the wall port and the other end to the **Cable In** port of the BMC.
4. To connect audio and video cables, refer to the diagram and instructions listed below that apply to your installation.

For this configuration	Go to
DVI-D and Digital Audio	Figure 4, pg 6
DVI-D and Stereo Audio	Figure 5, pg 7
Component Video and Digital Audio	Figure 6, pg 7
Component video and Stereo Audio	Figure 7, pg 8
S-Video and Stereo Audio	Figure 8, pg 8
Composite Video and Stereo Audio	Figure 9, pg 9

NOTE The DVI port on the BMC may not be enabled at this time. Once the port is enabled, you can reconnect your HDTV, provided it has an HDCP-compliant DVI port or connection.

To integrate additional devices into your configuration, such as a DVD player, VCR or Moxi Mate, refer to the manufacturer's documentation for each device.

Digital Video/Digital Audio Connection

1. Connect one end of the DVI-D cable to the **DVI-D** port of the BMC and the other end to the **DVI-D In** port of the TV or receiver.
2. Attach one end of the S/PDIF audio cable to the appropriate optical or coaxial **S/PDIF** port of the BMC and attach the other end to the **S/PDIF in** port of the TV or receiver.
3. Follow the instructions under "Installation Wrap-Up," starting on page 10.

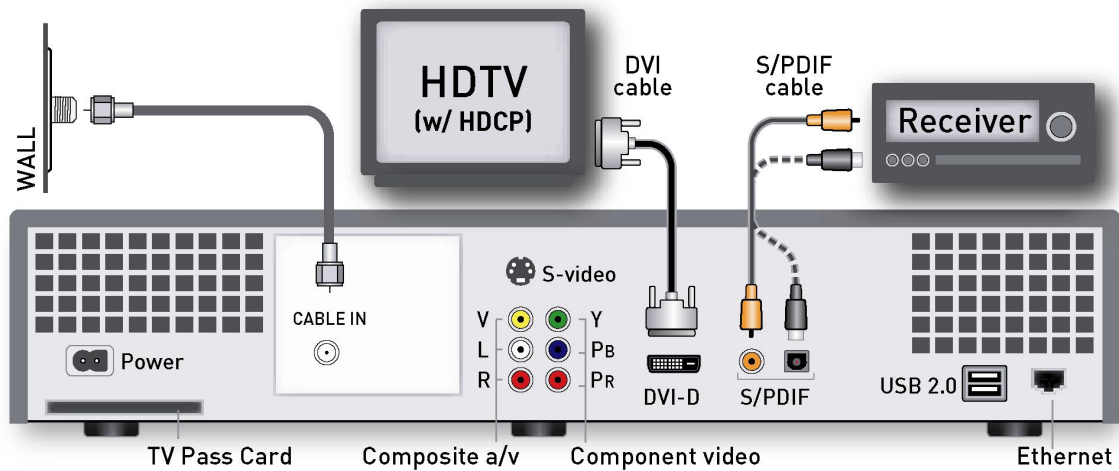

Figure 4: DVI-D digital video with S/PDIF digital audio

Digital Video/Stereo Audio Connection

1. Connect one end of the DVI-D cable to the **DVI-D** port of the BMC and the other end to the **DVI-D In** port of the TV or receiver.
2. Attach one end of the stereo audio cables to the Left (**L**) and Right (**R**) audio outputs of the BMC and the other end to the respective **L** and **R** inputs of the TV or receiver.
3. Follow the instructions under "Installation Wrap-Up," starting on page 10.

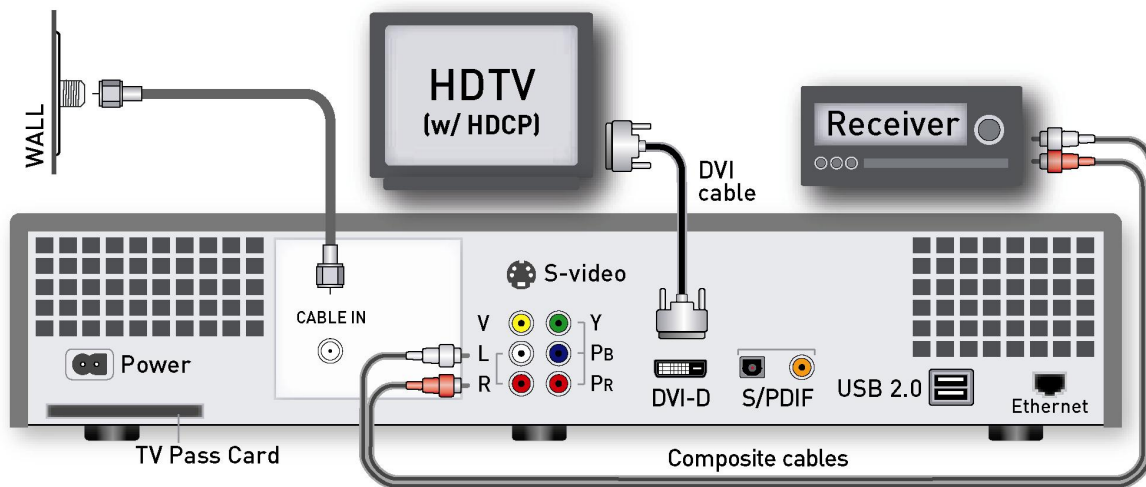

Figure 5: DVI-D digital video with stereo audio

Component Video/Digital Audio Connection

1. Connect component video cables from the **Y**, **PB**, and **PR** outputs on the BMC to the **Y**, **PB**, and **PR** inputs on the TV or receiver.
2. Attach one end of the S/PDIF audio cable to the appropriate optical or coaxial **S/PDIF** port of the BMC and attach the other end to the **S/PDIF** in port of the TV or receiver.
3. Follow the instructions under "Installation Wrap-Up," starting on page 10.

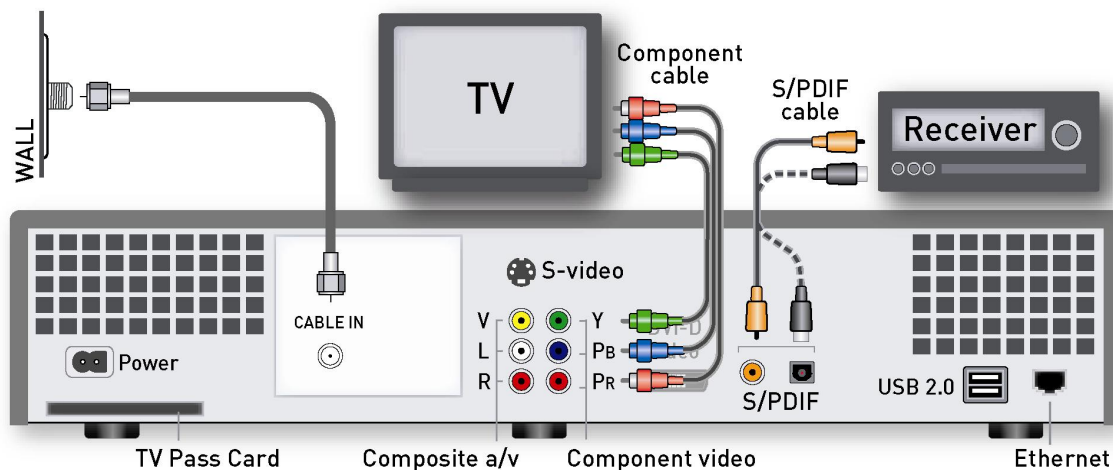

Figure 6: Component video with S/PDIF digital audio

Component Video/Stereo Audio Connection

1. Connect component video cables from the **Y**, **PB**, and **PR** outputs on the BMC to the **Y**, **PB**, and **PR** inputs on the TV or receiver.

2. Attach one end of the stereo audio cables to the Left (L) and Right (R) audio outputs of the BMC and the other end to the respective L and R inputs of the TV or receiver.
3. Follow the instructions under "Installation Wrap-Up," starting on page 10.

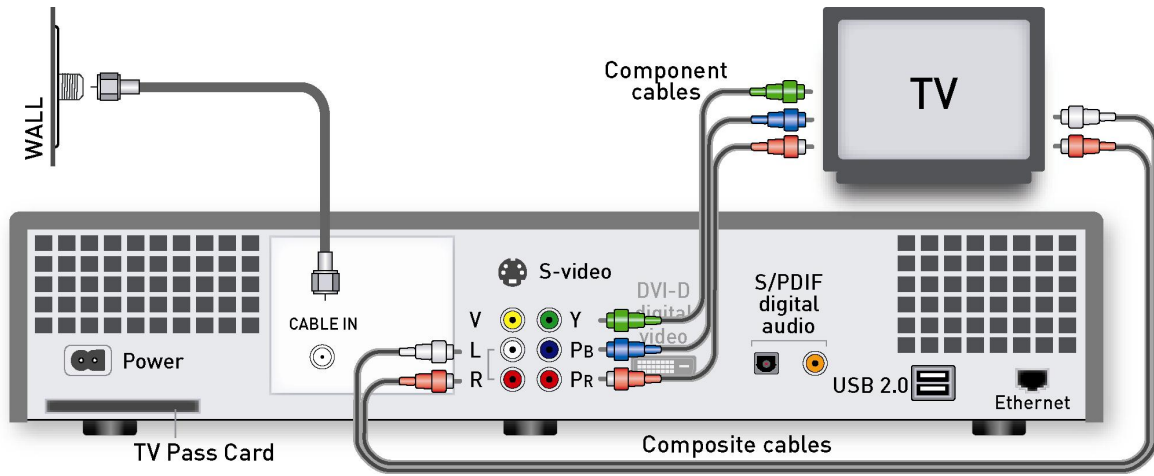

Figure 7: Component video with stereo audio

S-Video/Stereo Audio Connection

1. Connect one end of the S-Video cable to the **S-Video** port of the BMC and the other end to the **S-Video In** port of the TV or receiver.
2. Attach one end of the stereo audio cables to the Left (L) and Right (R) audio outputs of the BMC and the other end to the respective L and R audio inputs of the TV or receiver.
3. Follow the instructions under "Installation Wrap-Up," starting on page 10.

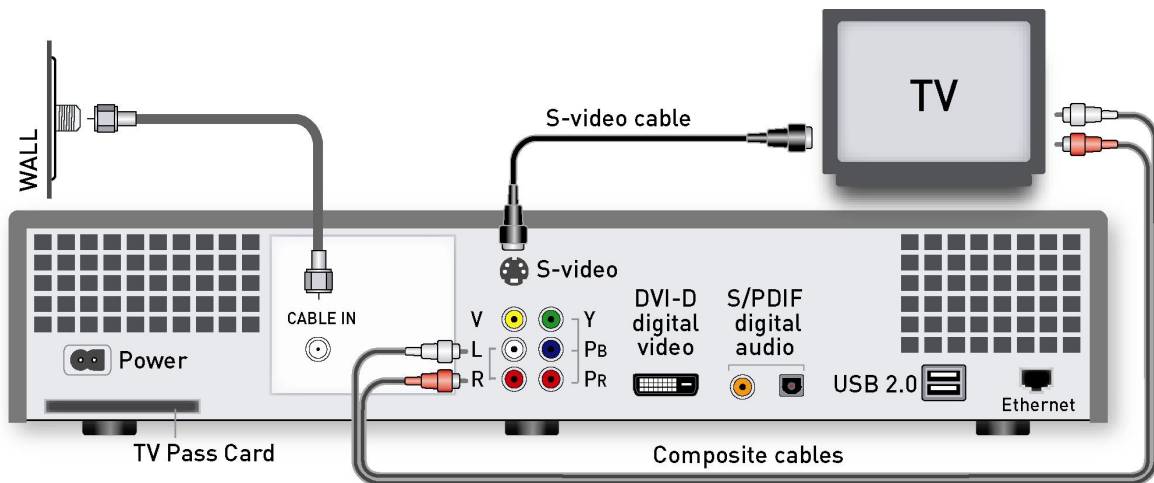

Figure 8: S-video with stereo audio

Composite Video/Stereo Audio Connection

1. Attach one end of a composite video cable to the video (**V**) output of the BMC and the other end to the **Video In** port of the main TV or receiver.
2. Attach one end of the stereo audio cables to the Left (**L**) and Right (**R**) audio outputs of the BMC and the other end to the respective **L** and **R** inputs of the TV or receiver.
3. Follow the instructions under "Installation Wrap-Up," starting on page 10.

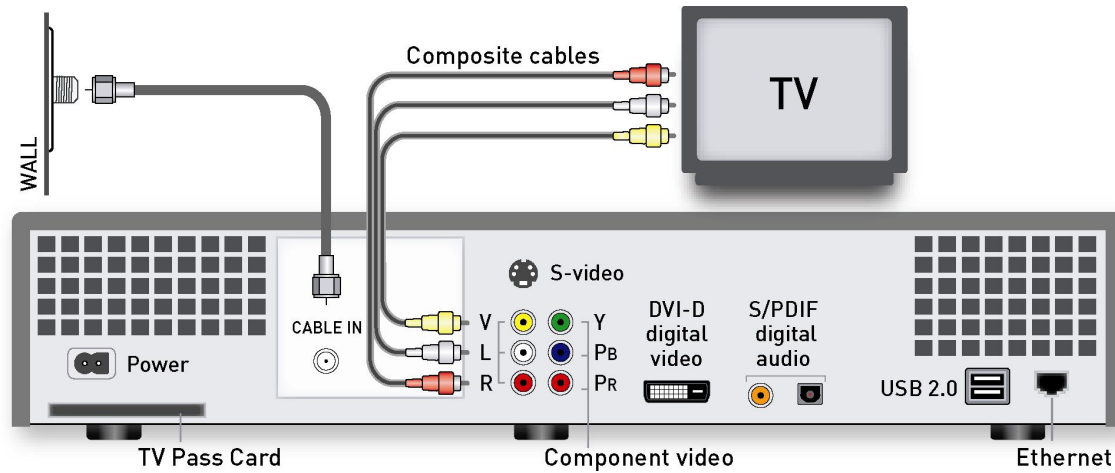

Figure 9: Composite video/stereo audio

Installation Wrap-Up

1. Verify that all cable connections are tight and secure, all coaxial connections are finger-tight and properly seated, and that all RCA-style plugs are fully seated.
2. Ensure that nothing blocks the vents of the BMC or other equipment.
3. Plug the TV power cord into the wall outlet.
4. Attach one end of the power cable to the BMC **Power** port and plug the other end into the wall outlet.

During the start-up process, a sequence of numbers may appear on the front panel display (where the time appears normally). This display is designed to help troubleshoot the system. If the BMC is unable to complete the startup process, please note the number shown on the display and refer to it when speaking with your cable provider's customer support representative.

Depending on the type of TV and connection used, you may need to tune the TV to the proper channel or set the video input source. Refer to your TV user manual for details.

The Moxi splash screen on the TV indicates a successful installation. Allow the unit approximately three minutes to fully start, and then configure the audio and video software settings using the information in the next two sections.

NOTE Once the BMC is turned on, you never need to turn it off. Unless you are moving the BMC or having it serviced, you should leave it powered on at all times to ensure that scheduled recordings are not interrupted.

Audio Configuration

When your cable company installs your system, they configure your audio setting for you. However, if you upgrade or change your sound system, you must reconfigure the BMC's audio output.

1. Press the **MOXI** button on the remote to bring up the Moxi Menu.
2. Go to **Settings** and choose **Digital Audio**.
3. Bring the desired setting into center focus, and then press **OK** to select it.
4. Choose one of the following:
 - If your system uses an S/PDIF connection, choose **Dolby Digital** for digital audio support.
 - If your system has a typical Red/White dual composite cable connection, choose **Stereo**.

The following table represents the audio format supported by each type of physical connection available on the BMC.

Supported Audio Formats

Audio connection	Supported audio	
	Stereo	Dolby Digital
S/PDIF Audio	✓	✓
Stereo Audio (L/R)	✓	

Video Configuration

If you switch between composite/S-video and component/DVI-D input connections, do the following before proceeding:

- Hook up the new cables WHILE KEEPING THE EXISTING CABLES CONNECTED.
 - If the new connection requires a different TV input, do not change it until step 4.
1. Press the **MOXI** button on the remote to bring up the Moxi Menu.
 2. Go to **Settings** and choose **Video Output**.
 3. Bring one of the following settings into center focus, and then press **OK** to select it.
 - If you have a high-definition (HD) compatible TV connected by a DVI-D or Component (Y, Pb, Pr) cable, select the **1080i** setting.
 - If your TV does not support 1080i, but supports other high-resolution settings, you can select either **480p** or **720p**. Remember that you must use a DVI-D or Component cable connection to support settings above 480i (see the video connections table).
 - If your TV does not support high-definition settings and is connected by an S-video cable or a composite video cable (the yellow-tipped RCA cable), select the **480i** setting. This is the default setting choice.

See your TV's user manual for the setting that is right for your TV.

4. When you select a video output setting, Moxi tries that setting for you. You may see a black screen while Moxi tries the new setting.
 - If you are switching between composite/S-video (480i setting) and component/DVI-D (480p, 720p, or 1080i setting) input connections, you may also need to switch your TV's input to match the new setting. If Moxi tries the setting before you have the correct TV input, the Video Output settings choices reappear on your original TV input. You must choose the new setting again.
 - If you are not switching between composite/S-video and component/DVI-D connections, you can confirm the new setting without changing TV inputs.

If you select a setting that is not supported, your screen may appear unreadable.

5. After Moxi tests the new setting, it asks you to confirm your new choice. If you don't confirm the new video output setting within 20 seconds, Moxi reverts to the previous one.

The following table lists the video resolutions supported by each type of physical connection available on the BMC.

Video connections: supported resolutions

Connection	Supported resolution			
	480i	480p	720p	1080i
DVI-D Digital Video		✓	✓	✓
Component Video	✓	✓	✓	✓
S-Video	✓			
Composite Video	✓			

Video Settings Definitions

p and i Designations

In video resolution settings, the "p" and "i" designations stand for "progressive" and "interlaced." These terms are used to describe how a TV picture is displayed on the screen.

Video Resolution Formats

720p and 1080i are High Definition (HD) formats. 480p and 480i are Standard Definition (SD) formats. 480i is roughly equivalent to a normal analog TV picture. Analog TV shows broadcast on digital TV stations are broadcast in 480p or 480i.

HD and SD Aspect Ratios

The aspect ratio is the ratio of the width of a TV picture to its height. HD shows use an aspect ratio of 16:9, also known as "widescreen." SD shows use an aspect ratio of 4:3.

TIP If you have HDTV, we suggest you set your video output for HD (usually 1080i). However, if you want to view SD shows in their original 4:3 ratio, we suggest you follow the instructions on the previous page to change your video output setting to 480i. After the show, you will want to change the setting back for HD.

Chapter 3

Moxi Remote

The Moxi remote allows you to access, control, and enjoy the many features of your Media Center. You can also use this remote as the primary remote for many brands of TVs and audio devices. Instructions in this chapter show you how. Refer to the *Moxi Viewer's Guide* for explanations of the buttons.

Your cable operator may provide a different remote. If your remote does not look like the one pictured here, refer to the manual your cable operator provided with the remote.

NOTE When replacing batteries, use only high quality, non-corrosive batteries designed for use in electronic equipment.

Programming Procedure

The Moxi remote operates the BMC, and—once programmed—will simultaneously control the *power*, *volume*, and *mute* functions of your TV or audio receiver. Use the following instructions to program the remote.

From the tables on the following pages, find the codes for your brand of TV or audio receiver and use this information with the "Programming by Code" procedure below. If your brand is not listed or if the given codes do not work, follow the instructions in the "Programming by Search" procedure on page 14.

Programming by Code

1. Turn on the TV or receiver you want the remote to control.
2. On the Moxi remote, press and hold the **MOXI** and **OK** buttons simultaneously until the LED light on the top of the remote blinks twice.
3. Using the number buttons on the remote, enter one of the codes for your device from the reference tables starting on page 14. When you enter the correct code, the LED blinks twice. (If it blinks once, the code was invalid—try again.)
4. Press the **Power** button on the remote. If the TV or receiver does not respond, repeat steps 2 and 3 using another listed code. Repeat until successful, or use the Programming by Search procedure.

NOTE To reset the remote to the original factory setting, enter code **9 9 9 9**, and then press **OK** in **step 3** above.



Figure 10: Moxi Remote

Programming by Search

1. Turn on the TV or receiver you want the remote to control.
2. On the Moxi remote, press and hold the **MOXI** and **OK** buttons simultaneously, until the LED light on the top of the remote blinks twice.
3. Using the number buttons on the remote, press **9 9 1 0** for TV, or **9 9 1 1** for audio receiver. The LED light blinks twice.
4. Press the **Mute** button.
 - If this mutes the device, go to step 5.
 - If this does not mute the device, press the **Up** arrow to advance to the next code, and then press **Mute** again. Repeat until the device responds.
5. Press **OK** to set the current code and finish.

NOTE Some older devices may not be supported. If the device still fails to respond, use its original remote to control it. Contact your cable provider's customer service for additional assistance.

Television Codes

TV Brand	Manufacturer Code	TV Brand	Manufacturer Code
3M	0737	A-Mark	0003
AOC	0030, 0003, 0052, 0137, 0185	Abex	0032
Admiral	0093, 0463	Advent	0761
Adventura	0046	Aiko	0092
Aiwa	0701	Akai	0030, 0098, 0591
Alaron	0179, 0183, 0216	Ambassador	0177
America Action	0180	Ampro	0751
Anam	0180, 0004, 0009, 0068	Anam National	0055, 0161
Apex Digital	0748, 0765, 0767	Archer	0003
Audinac	0391	Audiovox	0451, 0180, 0003, 0092, 0623, 0713
Baysonic	0180	Broksonic	0236, 0463, 0003, 0426, 0642
Bush	0355	CCE	0037, 0217, 0329
CXC	0180	Candle	0030, 0056, 0046, 0186
Carnivale	0030	Carver	0054, 0170
Casio	0611	Bell & Howell	0154, 0016
Bradford	0180	Celebrity	0000
Changhong	0765	Cineral	0451, 0092
Citizen	0060, 0030, 0056, 0039, 0046, 0092, 0186, 0280, 0561	Clairtone	0185
Compaq	0749	Concerto	0056
Contec	0180, 0157, 0158, 0185	Craig	0180, 0161
Crosley	0054	Crown	0180, 0039, 0672
Curtis Mathes	0047, 0054, 0154, 0451, 0093, 0060, 0030, 0145, 0056, 0016, 0039, 0166, 0415, 0466, 0702, 0747, 1147, 1347	Daewoo	0451, 0039, 0066, 0067, 0091, 0092, 0623
Denon	0145, 0511	Dumont	0017
Dwin	0720, 0774	Dynatech	0049
Ectec	0391	Eiki	0735
Electroband	0000, 0185	Electrohome	0381, 0389, 0409
Emerson	0154, 0236, 0463, 0180, 0282, 0178, 0179, 0039, 0038, 0158, 0177, 0181, 0182, 0183, 0185, 0270, 0280, 0623	Envision	0030
Fisher	0154, 0159	FlexVision	0713

TV Brand	Manufacturer Code	TV Brand	Manufacturer Code
Fujitsu	0179, 0683	Funai	0180, 0179, 0171
Futuretech	0180	GE	0047, 0051, 0451, 0282, 0178, 0021, 0055, 0027, 0029, 0135, 0279, 0747, 1147, 1347
Gibraltar	0017, 0030	GoldStar	0030, 0178, 0001, 0002, 0032, 0106, 0409
Goodmans	0360	Gradiente	0053, 0056, 0170, 0392
Grundig	0037	Grunpy	0180, 0179
Haier	0768	Hallmark	0178
Harley Davidson	0179, 0043	Harman/Kardon	0054, 0078
Harvard	0180, 0068	Hauptauge	0693
Havermy	0093	Hitachi	0145, 0056, 0016, 0032, 0038, 0095, 0097, 0151, 0173, 0227, 0279, 0409, 0413, 0576, 0577, 0583, 0723, 0770, 1145
InFocus	0736, 0738, 0741, 0752	Infinity	0054
Innova	0037	Inteq	0017
JBL	0054	JCB	0000
JVC	0053, 0036, 0069, 0160, 0169, 0182	Janeil	0046
Jensen	0050	KEC	0180
KMC	0106	KTV	0180, 0030, 0039, 0183, 0185, 0217, 0280
Kamp	0216	Kawasho	0158, 0216, 0308
Kaypani	0052	Kenwood	0030
Kloss	0024, 0046, 0078	Konka	0628, 0632, 0638, 0703, 0707
LG	0056, 0442	LXI	0047, 0054, 0154, 0156, 0178, 0148, 0747
Loewe	0136, 0633, 0693, 0694	Logik	0016
Luxman	0056	MEI	0185
MGA	0150, 0030, 0178, 0155	MTC	0060, 0030, 0056, 0049, 0091, 0185, 0216
Magnavox	0054, 0030, 0179, 0020, 0024, 0028, 0036, 0096, 0186, 0187, 0230, 0386, 1254, 1454	Majestic	0016, 0015
Marantz	0054, 0030, 0037, 0444, 1554	Matsushita	0250, 0650
Megatron	0178, 0145, 0003	Memorex	0154, 0250, 0463, 0150, 0178, 0179, 0016, 0106, 1037
Mercury	0001	Midland	0047, 0017, 0051, 0039, 0032, 0135, 0747
Minutz	0021	Mitsubishi	0093, 0150, 0178, 0014, 0098, 0155, 0331, 0358, 0592
Motorola	0093, 0055	Multitech	0180, 0049, 0217
NAD	0156, 0178, 0166	NEC	0030, 0056, 0036, 0170, 0434, 0455, 0704
NTC	0092	Nesa	0763
Netsat	0037	Nikko	0030, 0178, 0092, 0317
Nisato	0391	Noblex	0430
Noshi	0018	On Command	0531
Onwa	0180	Optimus	0154, 0250, 0166, 0650
Optiview	0756	Optonica	0093, 0165
Orion	0236, 0463, 0179	Ovation	0734
Panasonic	0250, 0051, 0055, 0162, 0226, 0650	Penney	0047, 0156, 0051, 0060, 0030, 0178, 0021, 0018, 0039, 0002, 0003, 0027, 0032, 0110, 0135, 0149, 0309, 0747, 1347
Philco	0054, 0463, 0030, 0145, 0020, 0028, 0096, 0302	Philips	0054, 0037, 1354, 1454

TV Brand	Manufacturer Code	TV Brand	Manufacturer Code
Pilot	0030, 0039	Pioneer	0038, 0166, 0172, 0679
Portland	0039, 0092	Princeton	0685, 0700, 0717
Prism	0051	Proscan	0047, 0747
Proton	0178, 0003, 0031, 0052, 0466	Proxima	0734, 0735, 0737, 0742, 0743
Pulsar	0017	Quasar	0250, 0051, 0165, 0055, 0219, 0650
RCA	0047, 0018, 0029, 0038, 0090, 0135, 0254, 0278, 0679, 0747, 1047, 1147, 1247, 1347, 1447, 1547	RadioShack	0047, 0154, 0165, 0180, 0030, 0178, 0056, 0039, 0032, 0409, 0747
Realistic	0154, 0165, 0180, 0030, 0178, 0056, 0039, 0032	Rhapsody	0183, 0185, 0216
Rosen	0756	Runco	0017, 0030, 0612
SKY	0037	SSS	0180
Sampo	0030, 0039, 0032, 0052, 0100, 0110	Samsung	0060, 0030, 0178, 0056, 0032, 0037, 0329, 0408, 0427, 0482, 0702, 0766
Samsux	0039	Sansei	0451
Sansui	0463	Sanyo	0154, 0088, 0107, 0146, 0159, 0232, 0484
Scotch	0178	Scott	0236, 0180, 0178, 0179, 0309
Sears	0047, 0054, 0154, 0156, 0178, 0179, 0056, 0015, 0146, 0148, 0149, 0159, 0168, 0171, 0281, 0747	Semivox	0180
Semp	0156	Sharp	0093, 0165, 0039, 0153, 0157, 0281, 0386, 0398, 0491, 0688
Signature	0016	Simpson	0186, 0187
Sinudyne	0347	Sony	0000, 0011, 0080, 0111, 0273, 0353, 1100
Soundesign	0180, 0178, 0179, 0186	Spectricon	0003, 0137
Squareview	0171	Starlite	0180
Supre-Macy	0046	Supreme	0000
Sylvania	0054, 0030, 0020, 0028, 0065, 0096, 0171, 0381	Symphonic	0180, 0171
TMK	0178, 0056, 0177	TNCi	0017
Tandy	0093	Tashiko	0588
Tatung	0055, 0003, 0049, 0396	Technics	0250, 0051
Technol Ace	0179	Techwood	0051, 0056, 0003
Teknika	0054, 0180, 0150, 0060, 0179, 0056, 0016, 0039, 0092, 0175, 0186, 0312	Telefunken	0056, 0101, 0702
Telemagic	0735	Tera	0031
Thomson	0209, 0210	Toshiba	0154, 0156, 0060, 0036, 0149, 0650, 1256, 1356
Tosonic	0185	Totevision	0039
Trical	0157	Ultra	0391
Universal	0027	Vector Research	0030
Victor	0053	Video Concepts	0098
Vidikron	0054, 0242	Vidtech	0178, 0036
ViewSonic	0724, 0775	Viking	0046, 0312
Wards	0054, 0165, 0030, 0178, 0021, 0179, 0056, 0016, 0020, 0027, 0028, 0029, 0080, 0096, 0111, 0202	Waycon	0156
White Westinghouse	0463, 0623	Yamaha	0030
Zenith	0017, 0463, 0016, 0092	Zonda	0003

Audio/Video Receiver Codes

Receiver Brand	Manufacturer Code	Receiver Brand	Manufacturer Code
ADC	3531	ADS	3375, 4157
Adcom	3002, 3304, 3319, 3616	Admiral	3182
Aiwa	4089, 4405, 3121, 3125, 3158, 3162, 3189, 3249, 3284, 3301, 3361, 3544, 3601, 3745, 4188, 4243, 4321, 4388, 4641	Akai	3076, 3115, 3151, 3224, 3450, 4255
Alco	4390	Arcam	4120, 4212, 4214, 4216
Audio Access	3403	Audio Authority	4256
AudioSource	3687	Audiotronic	4189
Audiovox	4390	B & K	3701, 3820, 3840
BK	3702	Bang & Olufsen	3898, 4040
Bondstec	3049	Bose	4229, 3238, 3639
Capetronic	3531, 3690	Carver	4089, 4189, 3008, 3042, 3189, 3270, 3360
Casio	3195, 3201	Celestion	4264
Clarinette	3195	Creek	3792
Counterpoint	3253	Curtis Mathes	3201
Daewoo	4250	Delphi	4201
Denon	4104, 3004, 3273, 3386, 3771, 4142, 4311, 4360, 4660	EAD	4045, 4046, 4047, 4048
Eclipse	4061	Emerson	3020, 3255, 3424, 3495
Enlightened Audio Designs	4045, 4046, 4047, 4048	Eroica	3051
Fisher	3042, 3219, 3360, 4801	GE	3260, 3649
GPX	3744, 4299	Garrard	3146, 3281, 3286, 3407, 3424, 3440, 3463, 3640, 3644, 3744
Glory Horse	4263	GoldStar	3057
Gradiente	3557	Hafler	3146
Hanwah	3741	Harman/Kardon	3110, 3189, 3891, 4004, 4005
Hitachi	3228, 3386, 3659, 4273	Inkel	3062, 3066
JBL	3110, 3794, 4002	JVC	3074, 3464, 4263, 4282, 4374
Jensen	3705, 3713, 3754	KLH	4138, 4390
Kansai	3440	Kenwood	4313, 4027, 4570, 4569, 3027, 3042, 3077, 3186, 3313, 3314, 3337, 4032, 4051, 4670
Koss	3255, 3424, 3495, 3624, 3636, 3744, 4366	LXI	3181, 3744, 3755
Lexicon	4076	Linn	3189
Lloyd's	3195	Luxman	3149, 3267, 3329, 3330, 3429, 3431
MCS	3039, 3044, 3201, 3346	Magnavox	4089, 4189, 3189, 3195, 3204, 3222, 3364, 3391, 3531
Marantz	4089, 4189, 3006, 3039, 3189, 3200, 3352, 3455, 4289, 4892	McIntosh	3258, 3619
McSilver	3466	Memorex	3335
Modulaire	3195	Museatex	3476
Musicmagic	4089	NAD	3320
NTDE Geniesom	3744	Nakamichi	3075, 3097, 3347, 3876
Nikko	3215, 3407, 3466, 3467, 3542, 3543, 3609	Niles	3413, 4173, 4174

Receiver Brand	Manufacturer Code	Receiver Brand	Manufacturer Code
Onkyo	3100, 3119, 3135, 3137, 3144, 3380, 3838, 3842, 4298	Optimus	4023, 3042, 3177, 3181, 3186, 3219, 3229, 3286, 3440, 3531, 3622, 3670, 3690, 3738, 3744, 3754, 3797, 3801, 3803, 3849, 4074
Orient Power	3744	Outlaw Audio	4109
Panasonic	4518, 3039, 3309, 3367, 3389, 4288, 4316, 4763, 4764	Panor	3350
Parasound	3549, 3895, 4124, 4238	Penney	3044, 3195, 3201, 3449
Philco	3479	Phillips	4089, 4189, 4269, 3189, 3391, 3620, 3642, 4120, 4268, 4283, 4368
Pioneer	4023, 3150, 3244, 3289, 3531, 3630, 4084, 4123, 4184, 4343, 4384	Polk Audio	3189, 4289
Proscan	4254	Proton	3026, 3047
Quasar	3039	RCA	4023, 4254, 3054, 3346, 3360, 3530, 3531, 3649, 4074, 4123, 4154, 4300, 4390, 4609
RDS	3242	RadioShack	3744, 4263
Realistic	3001, 3025, 3163, 3178, 3181, 3182, 3195, 3534	Rotel	3007, 3852
Revox	3140	SII	3355
STS	3217	Samsung	3069, 3070, 3112, 4295
Sansui	4089, 3148, 3189, 3193, 3323, 3346, 3593	Sanyo	3219, 3448, 3801, 4251
Schneider	3364	Scott	3105, 3163, 3322, 3390, 3396, 3418, 3449, 3495
Sears	3201	Semivox	3255
Sharp	3186, 3262, 4286, 4386	Sherwood	3062, 3066, 3324, 3475, 3491, 3502, 3565, 3653, 4066, 4077, 4653
Sonic	3281	Sontec	3068
Sony	4058, 4258, 4158, 3158, 3168, 3415, 3474, 3776, 4458, 4558, 4658, 4758	Soundesign	3670
Soundstream	3090	Stereophonics	4023
Sunfire	4313, 3313, 3314	Sylvania	3222
Symphonic	3182	Tandberg	3204, 3205
Teac	3112, 3163, 3298, 3387, 3463, 3870, 4074	Technics	4308, 4309, 4518, 3039, 3208, 3309
Techwood	3281, 3344, 3364, 3609	Thorens	4189
Topline	3767	Ultrx	3333, 3427
Vector Research	3218, 3352	Venturer	3849, 4390
Victor	3074	Wards	3054, 3158, 3189
Welton	3344	Yamaha	3081, 3082, 3176, 3186, 3293, 3545, 3712, 4176, 4276, 4376
Yorx	3195	Zenith	3281, 3511, 3622, 3705, 3736, 3744, 3857

Visit our website at:
www.motorola.com



519445-001
9/04

MGBI